



NGR02 Series

PRESSURE REDUCING REGULATORS
for Residential, Commercial or Industrial Applications



The NGR02 Series spring loaded gas regulators with internal relief provide consistent and controlled pressure in a variety of residential, industrial and commercial applications. The NGR02 is fully certified to ANSI Z21.80/CSA 6.22 for Class I, Class II, Vent Limiting and OPD (Overpressure Protection Device) applications and are designed to be used in many applications where non-corrosive dry gases are used.

FEATURES

- ANSI Z21.80/CSA 6.22 CERTIFIED
- Vent Limiting Option
- Internal Relief - OPD
- Outlet pressures up to 5 psig
- Conforms to ANSI B109.4
- Corrosion resistant exterior
- Inlet pressure tap standard

SPECIFICATIONS

Pipe Sizes:	1/2" to 1-1/4" NPT
Gas Types:	Natural Gas, LPG, other non-corrosive dry gases
Maximum Inlet Pressure:	10 to 125 psig per Orifice
Outlet Pressure Range:	2" w.c. to 5 psig
Maximum Emergency Inlet Pressure:	175 psig
Operating Temp:	-40F - +140F
Materials:	Housing: Epoxy Coated Aluminum Valve Body: Cast Iron Diaphragm/Valve Seat: Buna N Orifice: High Strength Brass

NGR02 Series PRESSURE REDUCING REGULATORS

7" w.c. Set Point - 1" Pressure Drop

Inlet Pressure	ORIFICE				
	1/8"	3/16"	1/4"	3/8"	1/2"
0.5	117	101	169	203	242
1	136	148	210	260	571
2	221	210	296	377	1039
3	234	257	460	468	1429
5	292	351	649	1169	1558
10	338	545	1091	1748	1740
15	390	701	1481	2104	
20	491	818	1870	2403	
30	619	1286	2571		
40	717	2260	3251		
50	805	2494	3636		
60	997	2571	4052		
80	1403	3696			
100	1675	4595			
125	1850	4812			

Green S02A and 1" VB used to develop table

14" w.c. Set Point - 2" Pressure Drop

Inlet Pressure	ORIFICE				
	1/8"	3/16"	1/4"	3/8"	1/2"
0.5					
1	156	94	187	285	584
2	182	156	292	325	1143
3	265	195	374	792	1688
5	335	234	592	1562	2013
10	386	390	1083	1792	2338
15	530	545	1535	2208	
20	600	623	2049	2338	
30	753	1558	2766		
40	922	2338	3384		
50	1052	2435	3701		
60	1183	2571	3896		
80	1403	3790			
100	1753	4749			
125	1900	5214			

Silver S02B and 1" VB used to develop table

1 psig Set Point - 20% Pressure Drop

Inlet Pressure	ORIFICE				
	1/8"	3/16"	1/4"	3/8"	1/2"
0.5					
1					
2	195	195	273	468	623
3	218	234	312	623	1013
5	234	351	506	857	1714
10	358	545	779	1870	3117
15	468	740	1091	2727	
20	545	857	1636	3429	
30	701	1247	2727		
40	584	2260	3740		
50	701	2338	4519		
60	779	2649	5143		
80	1558	3671			
100	2104	4570			
125	2250	5210			

Silver S02B and 1" VB used to develop table

2 psig Set Point - 20% Pressure Drop

Inlet Pressure	ORIFICE				
	1/8"	3/16"	1/4"	3/8"	1/2"
0.5					
1					
2					
3	187	179	234	351	429
5	265	257	390	545	1091
10	358	390	623	1169	2104
15	468	545	935	1714	
20	545	701	1403	2416	
30	701	935	2026		
40	1013	2026	3117		
50	1052	2182	3662		
60	1130	2260	4442		
80	1661	3271			
100	2150	4110			
125	2381	5170			

Yellow S02D and 1" VB used to develop table

5 psig Set Point (HP) - 20% Pressure Drop

Inlet Pressure	ORIFICE				
	1/8"	3/16"	1/4"	3/8"	1/2"
0.5					
1					
2					
3					
5					
10	273	468	701	1714	2805
15	351	655	1169	2494	
20	390	779	1792	3039	
30	468	1481	2571		
40	584	2338	3662		
50	662	2455	4364		
60	825	2494	5065		
80	1350	3752			
100	1467	4673			
125	1596	5794			

White (HP) S0204E and 1" VB used to develop table

Flow capacities in SCFH of 0.60 specific gravity gas @ 60° F and 14.7 psia. Individual results may vary.

Orifice Max Pressure

Size	Max Inlet Pressure	P/N
1/8"	125 psig	F02A
3/16"	125 psig	F02E
1/4"	60 psig	F02B
3/8"	20 psig	F02C
1/2"	10 psig	F02D

Spring Chart

Color	Outlet Range	P/N
Orange	2"wc - 7"wc	S02F
Green	6.5"wc - 16"wc	S02A
Silver	14"wc - 1psig	S02B
Yellow/Black	26"wc - 1.5psig	S02C
Yellow	1psig - 3psig	S02D
White (HP)	2psig - 5psig	S0204E

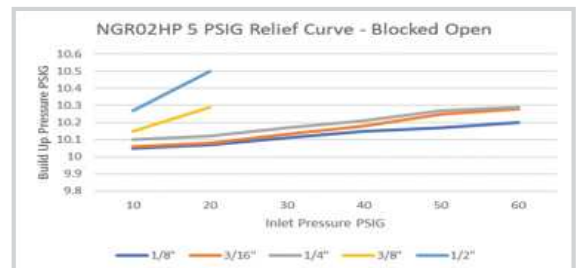
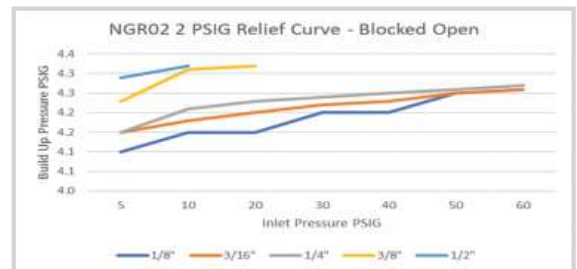
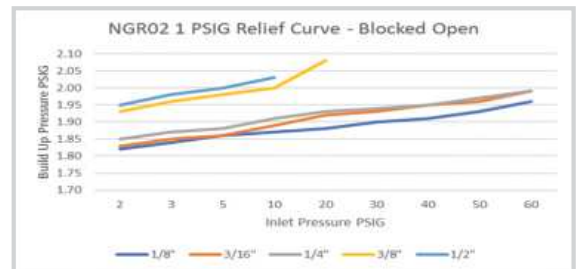
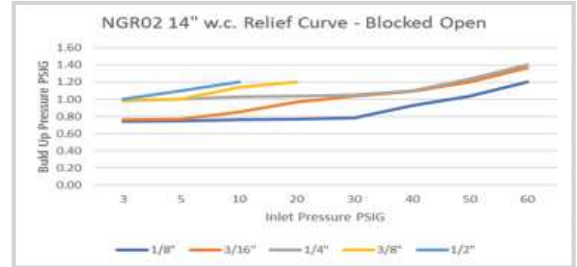
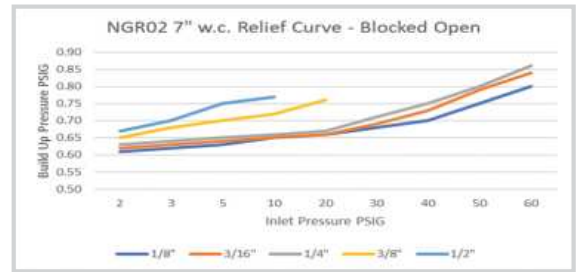

Blocked open relief curves developed using a 3/32" blockage across valve seat. Lever disconnect curves available upon request. Individual results may vary.

Gas Type	Specific Gravity	Correction Factor (CF)
Natural Gas	0.60	1.00
Propane	1.53	0.63
Air	1.00	0.77
Propane-Air-Mix	1.20	0.71
Nitrogen	0.97	0.79
Butane	2.01	0.55
Carbon Dioxide (Dry)	1.52	0.63
Carbon Monoxide (Dry)	0.97	0.79

Model	NGR02
Pipe Size	1/2", 3/4", 1", 1-1/4"
Vent (NPT)	1"
Wt. (lb)	3.75

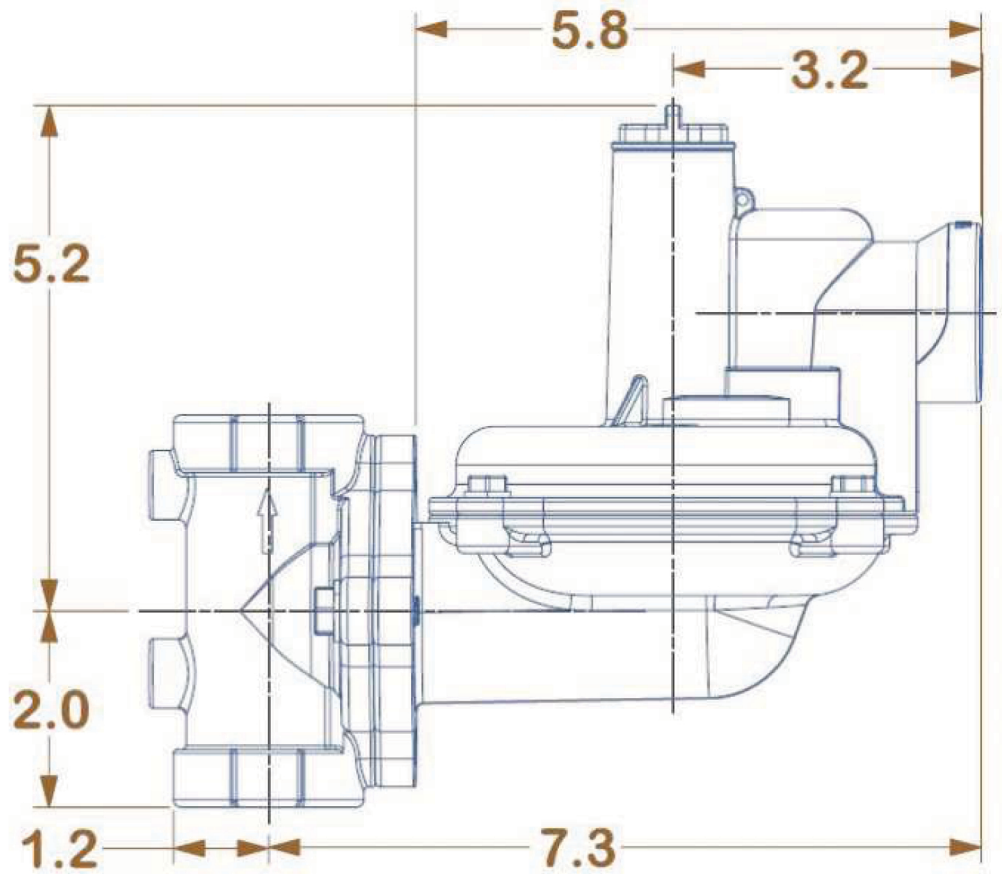

DISTRIBUTED BY: _____