



NGR08 Series

PRESSURE REDUCING REGULATORS
for Commercial or Industrial Applications

The NGR08 Series spring loaded gas regulators with internal relief provide consistent and controlled pressure in a variety of residential, industrial and commercial applications. The NGR08 is fully certified to ANSI Z21.80/CSA 6.22 for Class I, Class II, Vent Limiting and OPD (Overpressure Protection Device) applications and are designed to be used in many applications where non-corrosive dry gases are used.



FEATURES

- **ANSI Z21.80/CSA 6.22 CERTIFIED**
- Vent Limiting Option
- Internal Relief - OPD
- Outlet pressures up to 7 psig
- Conforms to ANSI B109.4
- Corrosion resistant exterior
- Inlet pressure tap standard

SPECIFICATIONS

Pipe Sizes:	1-1/4" NPT to 3" FL
Gas Types:	Natural Gas, LPG, other non-corrosive dry gases
Maximum Inlet Pressure:	25 to 125 psig per Orifice
Outlet Pressure Range:	2"w.c. to 7 psig
Maximum Emergency Inlet Pressure:	175 psig
Operating Temp:	-40F - +140F
Materials:	Housing: Epoxy Coated Aluminum Valve Body: Cast Iron Diaphragm/Valve Seat: Buna N Orifice: High Strength Brass

NGR08 Series PRESSURE REDUCING REGULATORS

7" w.c. Set Point - 1" Pressure Drop

Inlet Pressure	ORIFICE							
	1/4"	3/8"	1/2"	5/8"	3/4"	1"	1-1/4"	1-3/8"
1	390	857	982	2104	2961	4208	4286	6234
2	545	1403	1543	3039	3818	5143	7636	8961
3	701	1714	1964	3896	4831	5766	9039	9896
5	1013	2494	2665	5455	6390	6701	11610	12779
8	1247	3195	5844	7169	9662	12857	16364	17532
10	1558	3662	6468	8961	11065	15662	18701	21662
20	2182	5377	9818	14182	19558	20260	26883	37403
30	3117	7013	12779	19481	25169	25714	32338	
40	3896	8416	16753	23377	27273	27662	37403	
50	4831	9818	21506	25325	28501	28675		
60	5922	11221	27273	33662	33850	34121		
70	6692	13372						
90	8446	16626						
125	11512	22308						

Green S0608B and 2" VB used to develop table

14" w.c. Set Point - 2" Pressure Drop

Inlet Pressure	ORIFICE							
	1/4"	3/8"	1/2"	5/8"	3/4"	1"	1-1/4"	1-3/8"
1	360	550	940	1400	1950	2760	3020	4050
2	460	1280	2340	2570	3510	4050	5440	6080
3	540	1720	3040	3580	4050	6000	7480	7710
5	700	2570	4280	5380	5840	7790	8800	9520
8	1090	3430	5530	6620	7280	11180	12460	13950
10	1210	3890	6930	7550	8400	13240	13870	16750
20	2340	5840	9580	12070	13000	18710	21810	28400
30	3200	7250	12230	15580	18000	24200	25490	
40	3900	8730	14180	18390	22600	25960	27180	
50	4160	10050	16670	22600	26200	26880		
60	5370	11380	18700	24540	27900	28440		
70	5922	13948						
90	7668	17490						
125	10341	23587						

Purple S0608C and 2" VB used to develop table

1 psig Set Point - 20% Pressure Drop

Inlet Pressure	ORIFICE							
	1/4"	3/8"	1/2"	5/8"	3/4"	1"	1-1/4"	1-3/8"
1								
2	390	935	1948	2026	2571	3429	5688	5143
3	468	1091	2338	3195	3584	5143	7714	7013
5	545	1636	3117	4831	5299	9039	10130	10052
8	935	2494	4675	6857	8541	10675	15584	14416
10	1403	3273	5065	8260	13569	18701	20260	15195
20	2104	5221	9896	14026	16542	22584	23377	31403
30	2805	6935	13870	20554	21410	25412	29223	
40	4130	8961	15584	23563	26571	28961	30211	
50	5610	9273	20104	26523	28831	38386		
60	6319	12089	24054	33839	36296	41113		
70	7366	13870						
90	9461	17387						
125	13093	23475						

Silver S0608E and 2" VB used to develop table

2 psig Set Point - 20% Pressure Drop

Inlet Pressure	ORIFICE							
	1/4"	3/8"	1/2"	5/8"	3/4"	1"	1-1/4"	1-3/8"
1								
2								
3	390	623	2182	2494	3506	5123	5844	6701
5	545	1792	3506	5377	6156	9105	9351	9974
8	857	2805	4909	7523	7792	14412	15584	15650
10	1169	3584	6234	9156	9818	16520	17143	17456
20	1870	5455	9974	13253	14571	21105	21818	22597
30	2727	7247	14571	15486	17766	25545	25714	
40	3506	8571	18701	24432	26494	31008	31169	
50	4364	10130	28052	31001	31169	38440		
60	5209	12511	30778	35227	36412	43618		
70	6032	14186						
90	7666	17648						
125	10524	23726						

Silver S0608E and 2" VB used to develop table

5 psig Set Point - 20% Pressure Drop

Inlet Pressure	O R I F I C E							
	1/4"	3/8"	1/2"	5/8"	3/4"	1"	1-1/4"	1-3/8"
1								
2								
3								
5								
8	857	2416	3818	6078	7636	7792	12312	18701
10	1247	2727	5065	8961	9896	12078	15195	25403
20	2494	5221	8416	16286	17143	25714	33506	35065
30	3039	6779	12935	25325	33117	35651	38741	
40	3896	8571	16364	28051	35121	37874	43025	
50	4519	10052	20260	32338	37543	39512		
60	5542	12151	24206	32961	38837	44546		
70	6297	13924						
90	7788	17307						
125	10626	23541						

White S0608G and 2" VB used to develop table

Flow capacities in SCFH of 0.60 specific gravity gas @ 60° F and 14.7 psia. Boost Ring set at 0. Individual results may vary.

Orifice Max Pressure

Size	Max Inlet Pressure	P/N
1/4"	125 psig	F08A
3/8"	125 psig	F08B
1/2"	60 psig	F08C
5/8"	60 psig	F08D
3/4"	60 psig	F08E
1"	60 psig	F08F
1-1/4"	40 psig	F08G
1-3/8"	25 psig	F08H

Spring Chart

Color	Outlet Range	P/N
Orange	2"wc - 4"wc	S0608A
Green	5"wc - 8"wc	S0608B
Black	8"wc - 18"wc	S0608C
Purple	13"wc - 24"wc	S0608D
Silver	1 psig - 2 psig	S0608E
Yellow	2 psig - 4 psig	S0608F
White	4 psig - 7 psig	S0608G

Gas Type	Specific Gravity	Correction Factor (CF)
Natural Gas	0.60	1.00
Propane	1.53	0.63
Air	1.00	0.77
Propane-Air-Mix	1.20	0.71
Nitrogen	0.97	0.79
Butane	2.01	0.55
Carbon Dioxide (Dry)	1.52	0.63
Carbon Monoxide (Dry)	0.97	0.79

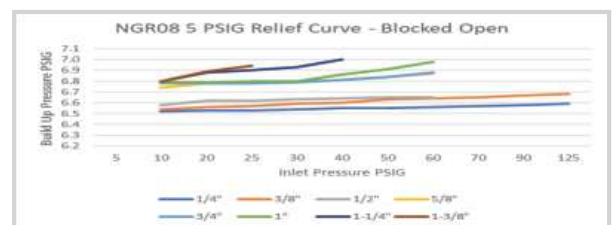
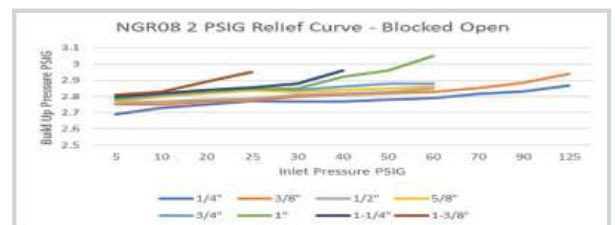
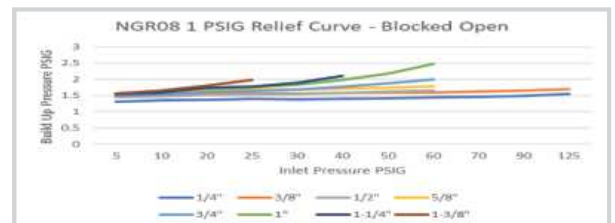
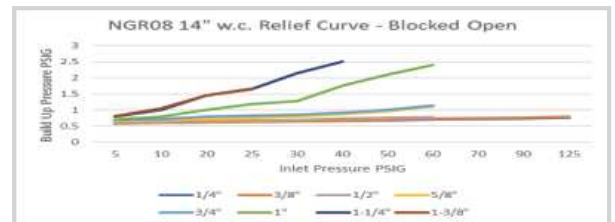
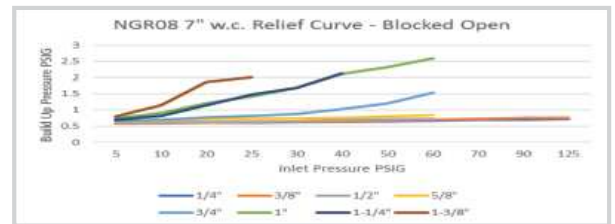

Blocked open relief curves developed using a 3/32" blockage across valve seat. Lever disconnect curves available upon request. Individual results may vary.

Model	Pipe Size	Vent (NPT)	Wt. (lb)
NGR08	1-1/4", 1-1/2", 2"	1"	25.30
	2" FL		35.00
	3" FL		47.80

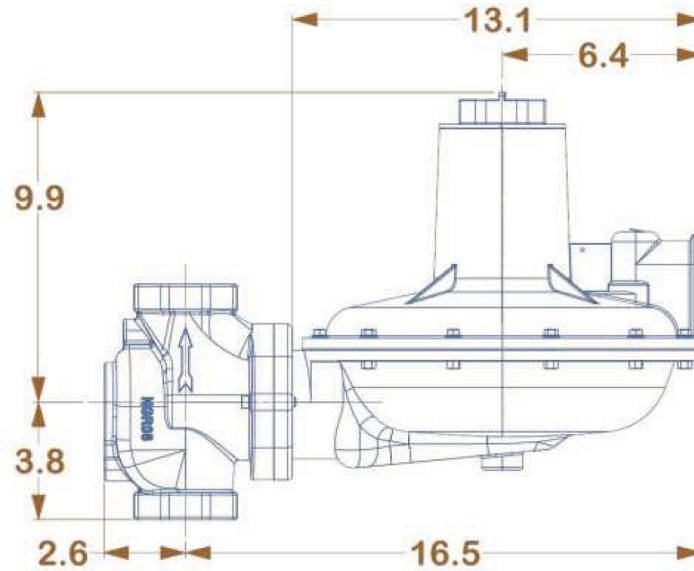

Flange to Flange (2" & 3"): 10"

DISTRIBUTED BY: